



Mazda 323



Experience sportiness the way_

it was meant to be. With the Mazda 323.



Sports are a form of pleasure, according to an old adage. And a sporty car is the best way to experience this pleasure on the road. Don't you agree? That's what the engineers at Mazda think, too. The Mazda 323 embodies this concept of sporty, fun driving. With a range of performance engines to choose from, the Mazda 323 shines no matter

what situation you put it in. However it's not the sheer numbers that impress so much as the spirited soul lurking inside. Complementing the engines is a high level of comfort and an improved stance, both of which ensure optimal driving fun even on those less than friendly road surfaces. Go ahead: experience sportiness the way it was meant

to be. With the Mazda 323. And to top it all off in an independent poll, the Mazda 323 was voted the most reliable car on Germany's roads* (by perhaps the most demanding drivers on the planet), so who are we to argue?

* "auto motor und sport" 12/99





Life

- 02 | 03 Sportiness is standard equipment.
- 04 | 09 A personal relationship.
- 10 | 11 Power...
- 12 | 13 ...and how it meets the road.
- 14 | 15 Safety from every angle.
- 18 | 19 A space of your own.
- 20 | 21 Impressively equipped.
- 22 | 23 The Sport.
- 24 | 25 A classic Mazda.
- 26 | 27 Past and future legends.





A photograph of a beach with sand dunes and driftwood. The sky is overcast and grey. The foreground shows dark, wet sand and some sparse vegetation. In the middle ground, there are sand dunes with patches of dry, yellowish grass and a large piece of driftwood lying on the sand. The background shows a hazy horizon where the beach meets the sea.

Relax



Mazda 323

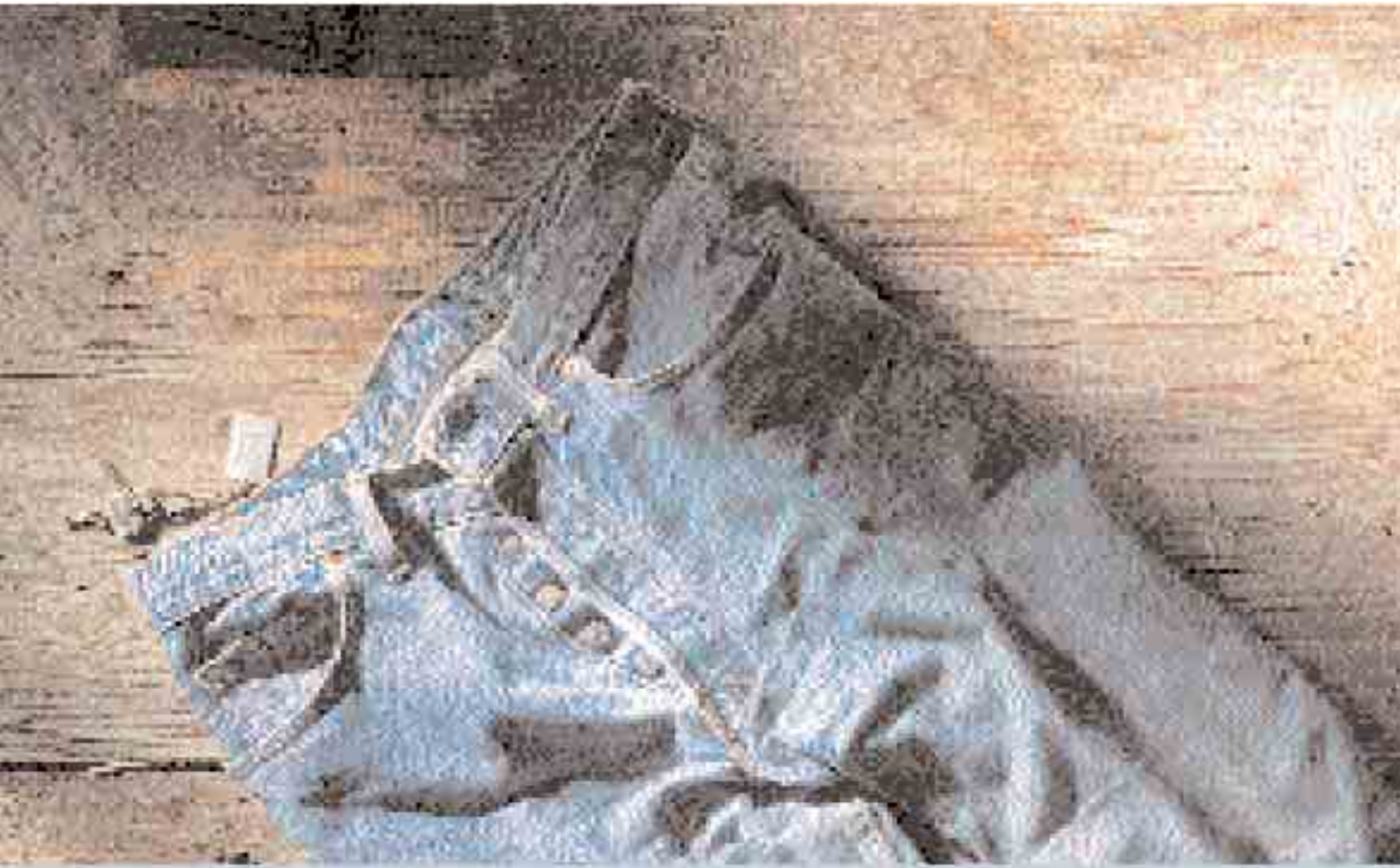

The Mazda 323. The more you use it,
the better it gets.



Like a good pair of denim jeans, the Mazda 323 is built to last. And just like your favourite garment, the longer you wear it the more it grows on you. It's a car you can take almost anywhere and do just about anything in. It never seems out of place in any situation and no task seems too much trouble. In fact, the more you get to know it, the more you'll find yourself looking for uses for the Mazda 323's wonderfully versatile qualities.

If you're the busy active type who never knows what's going to happen next in their life, the Mazda 323 could be the perfect solution. And with this latest, stylish generation, there's such a varied selection of engine options, interior trims and body styles to choose from, it should be easy to find a Mazda 323 that's a perfect fit.







The beauty of driving a car that feels as agile and manoeuvrable as the Mazda 323 is that it can turn the most mundane journey into a pleasure cruise. Whether you're dashing across town or zooming across country, you'll appreciate having extra power on hand from our range of engines – just what you need to take full advantage of the Mazda 323's superb handling and sure-footed

grip. Steering is light and precise, with just the right amount of feedback. Braking performance has also been enhanced, adding to your confidence and enjoyment of the drive.

Whoosh

Follow your instincts.

- Choose from three powerful new 16-valve petrol engines – 1.3 litre 72 ps, 1.6 litre 98 ps or 2.0 litre 130 ps.
- The Mazda 323's advanced new 2.0 litre turbo diesel engine develops 100 ps and 230 Nm of torque between 2000 and 2600 rpm.
- The independent suspension features MacPherson struts with coil springs at the front and Mazda's twin trapezoidal link at the rear.
- Choose between a light, precise 5-speed manual gearbox or a smooth 4-speed automatic transmission on the 1.6 GSi.

The Mazda 323 offers a choice of three powerful new petrol engine variants, in addition to an advanced turbo diesel engine design. There's an economical 1.3 litre 72 ps unit, an agile 1.6 litre 98 ps design and at the top of the range is a powerful new 2.0 litre engine developing an impressive 130 ps – test drive this model and you'll find that driving has never felt sportier. All three designs use 16 valves

for increased power and more efficient combustion. Diesel fans will appreciate having 100 ps on tap from the turbo diesel engine which is equipped with Variable Geometry Turbine (VGT) giving improved torque and throttle response at all speeds. But whichever power configuration you opt for, you'll find your Mazda 323 possesses one of the quietest-running engines in its class.

Precision power.

Subtle control.

To complement the Mazda 323's increased power and torque, its handling and ride control are second to none. The MacPherson strut layout has been coupled with a suspension geometry

that allows maximum tyre-to-road contact under all load conditions. And now the Mazda 323 also boasts an improved roll axis for impressive cornering stability.

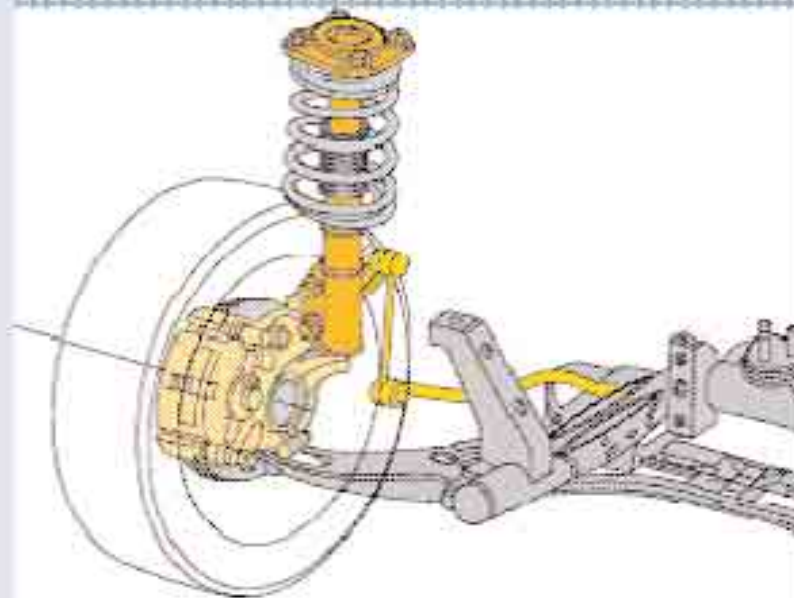



Nothing left to chance.



From the very start, safety has been a crucial consideration in the design and evolution of the Mazda 323. An impressive array of active safety features have been incorporated, features that are designed to help you avoid an accident in the first place.

For example, ABS braking with Electronic Brakeforce Distribution (EBD), standard across the range, can improve stopping distances and bring you safely to a halt in an emergency. Traction Control System (TCS) and Dynamic Stability Control (DSC), available on certain models, also help to prevent loss of control in critical situations. Clear, functional instrumentation and a wide field of view are further valuable aids to safety, giving the driver added confidence in difficult driving conditions.

Parents with small children will also appreciate features like the Mazda Airbag Deactivation System, which automatically senses when the front passenger seat is not occupied and also senses the presence of the exclusive Mazda system-compatible child seat[†] and then deactivates the airbags and seatbelt pretensioner on the passenger side. The Mazda 323 also has child-seat ISOFIX anchorages. These make fitting and removing child seats a simple operation.

Dynamic Stability Control (DCS), Traction Control System (TCS) and a passenger-seat airbag cancel system contribute to both safer driving and peace of mind.

^{††} This child seat is only available from Mazda dealers.



All round impact protection is ensured by the presence of driver, passenger and side airbags.



The Mazda 323's triple-H body construction gives strength where it's needed most – around the passenger cell.

Should an accident occur, a range of passive safety features come into play. The Mazda 323 has twin front airbags and side airbags as standard to protect against lateral impacts. Its supercomputer-designed triple-H body construction spreads the stresses of a

collision throughout the surrounding structure, creating a protective passenger cell and minimising damage at the point of impact. The Mazda 323 has undergone full head-on and offset crash tests to prove its ability to absorb frontal impacts and passed with flying colours.

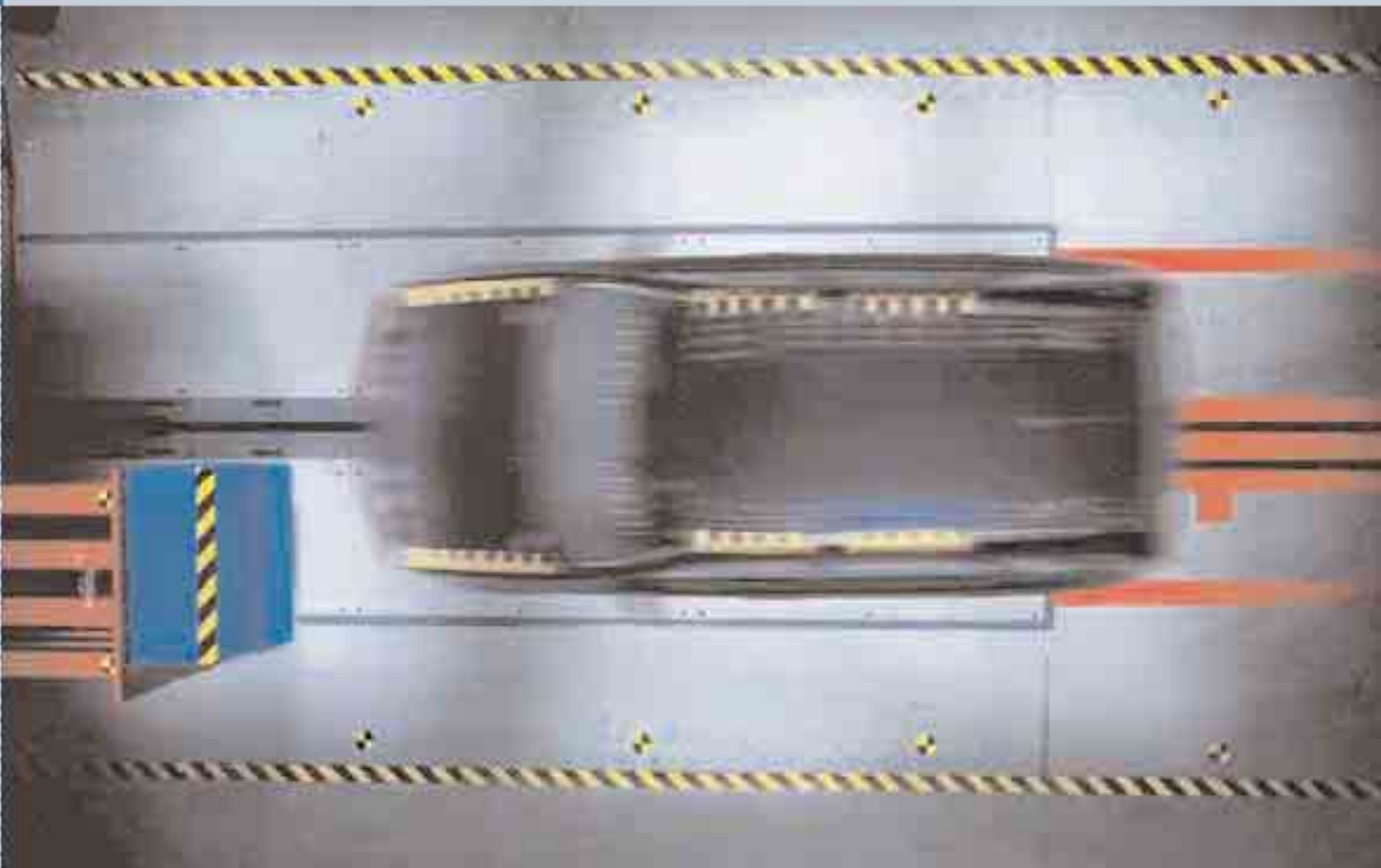





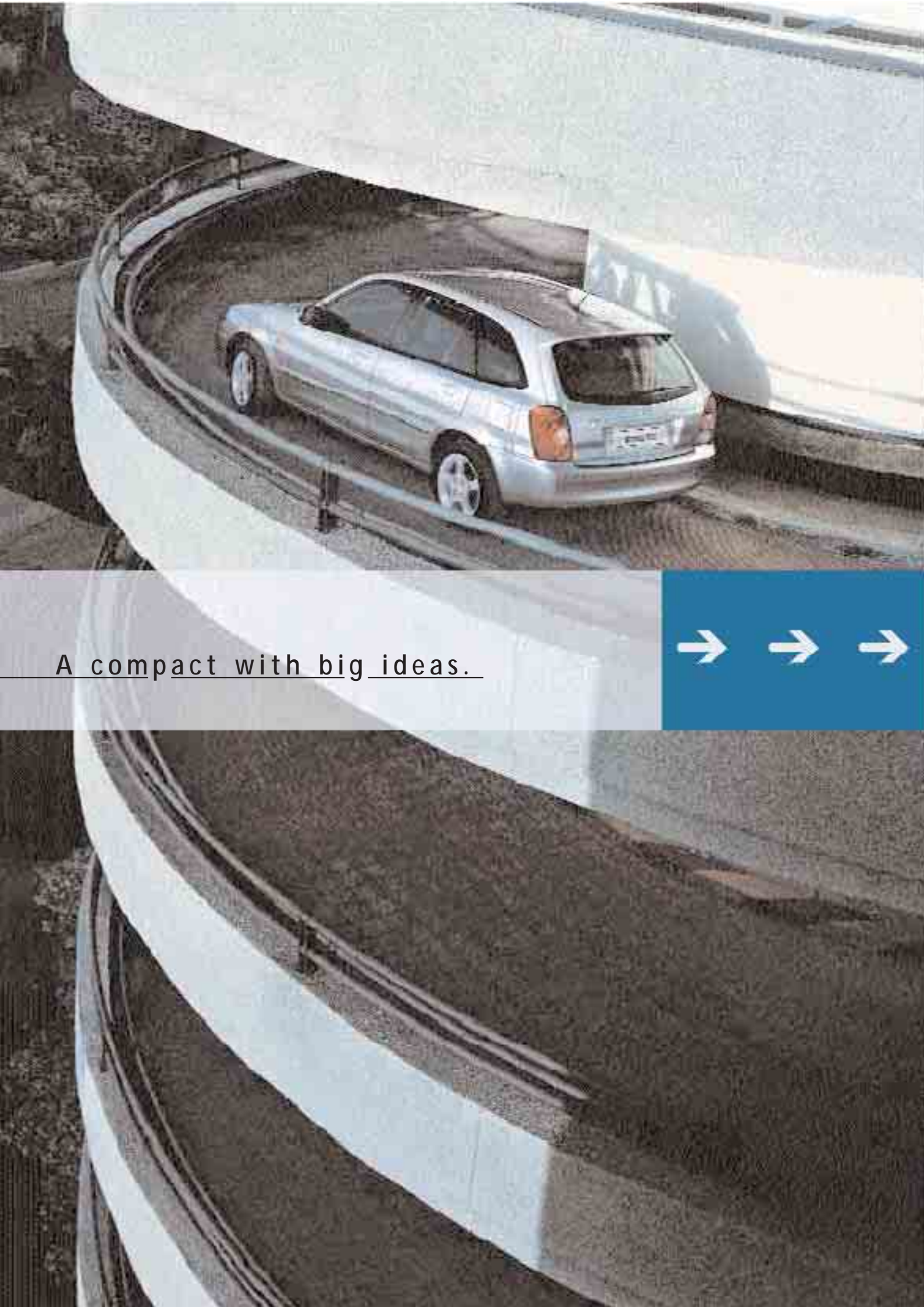

A compact with big ideas.



Practical: front passenger seat back folds into a table.*



Slidable rear seats* for extra legroom or luggage space.



Inside, you'll find the Mazda 323 is as flexible as your day demands - shop until you drop, help a friend move flats or pick up the folks for a weekend visit. The split rear seats allow maximum use of load space (a surprising 756 litres with both seats fully folded). They can

even recline independently for increased comfort on long journeys and they're also slidable fore and aft to allow more legroom or extra luggage space. Even the front passenger seat gets in on the act. It folds forwards to become a useful table surface.



Comfortable on long drives: reclining rear seats*.



Split slide rear seats* allows maximum use of space.

* GSi models only.



Features



At the touch of a button: front and rear electric windows.*



Convenient: radio controls on the steering wheel



Smooth, automatic transmission.
The ultimate driving luxury (option on GSi).



Practical and comfortable cabin layout.

* Selected models only.

*May not be to UK specification.

The Mazda 323 features our Modular Audio System which offers a spectacular nine-way range of choices including a CD player, mini disc player and radio cassette.

Outstanding sound quality is common to each unit, as has a built-in anti-theft protection because each module can only be used in a Mazda car.



Modular Audio System fitted with radio and cassette.



Modular Audio System fitted with radio, minidisc and CD player. (Options available at additional cost.)



Modular Audio System fitted with radio and minidisc player. (Options available at additional cost.)

Richly equipped, the Mazda 323 offers a remarkable level of specification for a car of this class. We think we've thought of everything: selected models feature front electric windows,

electric mirrors, air-conditioning, foglamps, height-adjustable driver's seat and rear speakers for sparkling sounds on your journey.



Sporty appearance: 185 R 15 tyres mounted on 15-inch alloys*.
(Standard on GSi).

* Not available on 1.3 models.



Time saver: remote-control door locking with double lock†.

† Selected models only.



Air-conditioning†.



Sport

Feel the dynamic spirit.

The Mazda 2.0 litre 323 Sport is a car with an appetite for driving that is more than matched by its looks. Outside it makes no secret of its stylish new character with its unique grille shape, 16" alloy wheels, sweeping front bumper with inset foglamps and aerodynamic side spoiler. Open the driver's door and the theme continues with polished scuff plates, leather steering-wheel and leather gear knob.

The dashboard sports a range of racy, white-faced dials, a Modular Audio radio single CD player and automatic air-conditioning controls. Rear electric windows and remote control central door locking complete the Sport's comprehensive feature list. And for extra safety the built-in Dynamic Stability Control (DSC) helps to prevent loss of control in critical situations.

Satellite Navigation not available in the UK





Sports-style, white meter cluster with amber-red illumination.



Smart, chrome door-sill scuff plate.

The compact and dynamic exterior of the Mazda 323, with its distinctive grille and striking headlights, creates a salient contrast to the large and comfortable interior. Its timeless appeal reflects the successful union of tranquil elegance with a high level of functionality. Thus the Mazda 323 enjoys a personality that clearly sets it apart from its rivals.

The new Mazda 323 has all the style and individuality that you expect from the Mazda stable. The car's sloping roof adds to its aerodynamic performance, as does the distinctive rear spoiler.

One look at the Mazda 323 will tell you that this car is as stunning as it is distinctive.

A classic Mazda

from stem to stern.





Stylish, sweeping new lines of bonnet.



Body-coloured electric door mirrors*. Heated for a clearer view.



Remote release fuel flap.



Aerodynamic rear spoiler.



The legendary Mazda MX-5 has achieved the rare distinction of becoming a legend in its own lifetime. Developed as a light, agile, affordable two-seater in the original roadster tradition, more than 600,000 have been sold since its first release in 1989. It has even made it into

the Guinness Book of World Records as the best selling roadster. This open-topped sports car has become synonymous with fun and freedom on the road. As an integral part of the Mazda family, you can be sure that some of its sporting spirit has rubbed off

onto its more practical sister, the new Mazda 323. Both cars were designed and tested using the same uncompromising approach to levels of performance and quality of construction – perhaps that's why both have become such firm, worldwide favourites.

Learning from the future.

Mazda's Design and Research Centre is the home of some of the most astonishing ideas in motor vehicle style and engineering. But innovative materials and eye-popping shapes are only part of the story. It's here that advanced research takes place into high-performance engines and wind-cheating silhouettes. The centre also develops the complementary safety systems to help protect drivers and passengers of the future.





Responsibility for the future has a lot to do with selecting the proper car. As an accountable automobile manufacturer, from the design phase the wise use of natural resources has been a primary objective for Mazda. But as important as ecology is, we're interested in more than maintaining a clean environment. We're also focused on the longevity of our cars. That's why we employ the highest manufacturing standards and specifications.

No wonder Mazda has a reputation for absolute reliability. It's well deserved. Our warranties include:

1. A three year/60,000 mile new vehicle warranty*.
2. A three year unlimited mileage paint and surface corrosion warranty.
3. A six year unlimited mileage anti-perforation warranty.
4. A three year European roadside assistance package.

* Unlimited mileage during the first year.

THE MAZDA 323



Your Mazda dealer:

For further information please see your Mazda dealer. Cars shown for illustrative purposes only and may differ from UK specification. Mazda Motors (UK) Limited reserves the right to introduce at any time alterations in design or construction, changes of detail, equipment and accessories. To avoid any misunderstanding any person interested in purchasing a vehicle should enquire of a Mazda dealer as to whether there have been any material alterations since the date of issue of this brochure, July 2002.

Internet: www.mazda.co.uk

Mazda hotline: 08457 484848